

ISSUE DATES:		
NO.	ISSUE	DATE

PRELIMINARY - NOT FOR CONSTRUCTION

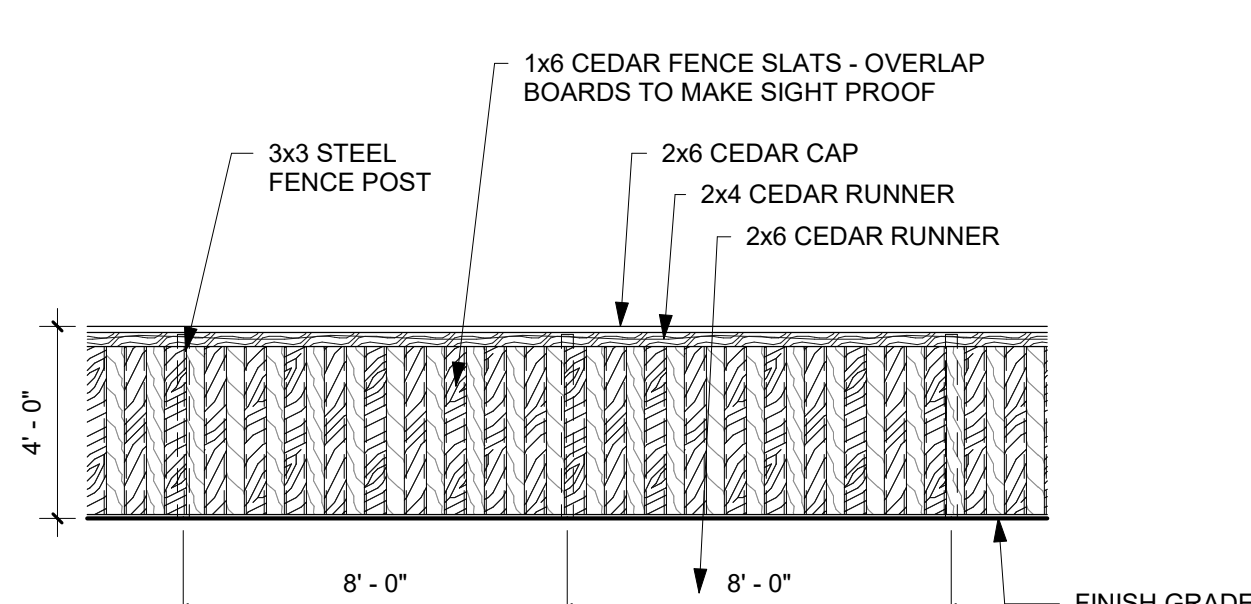

C CEDAR FENCE ELEVATION
 1/4" = 1'-0"

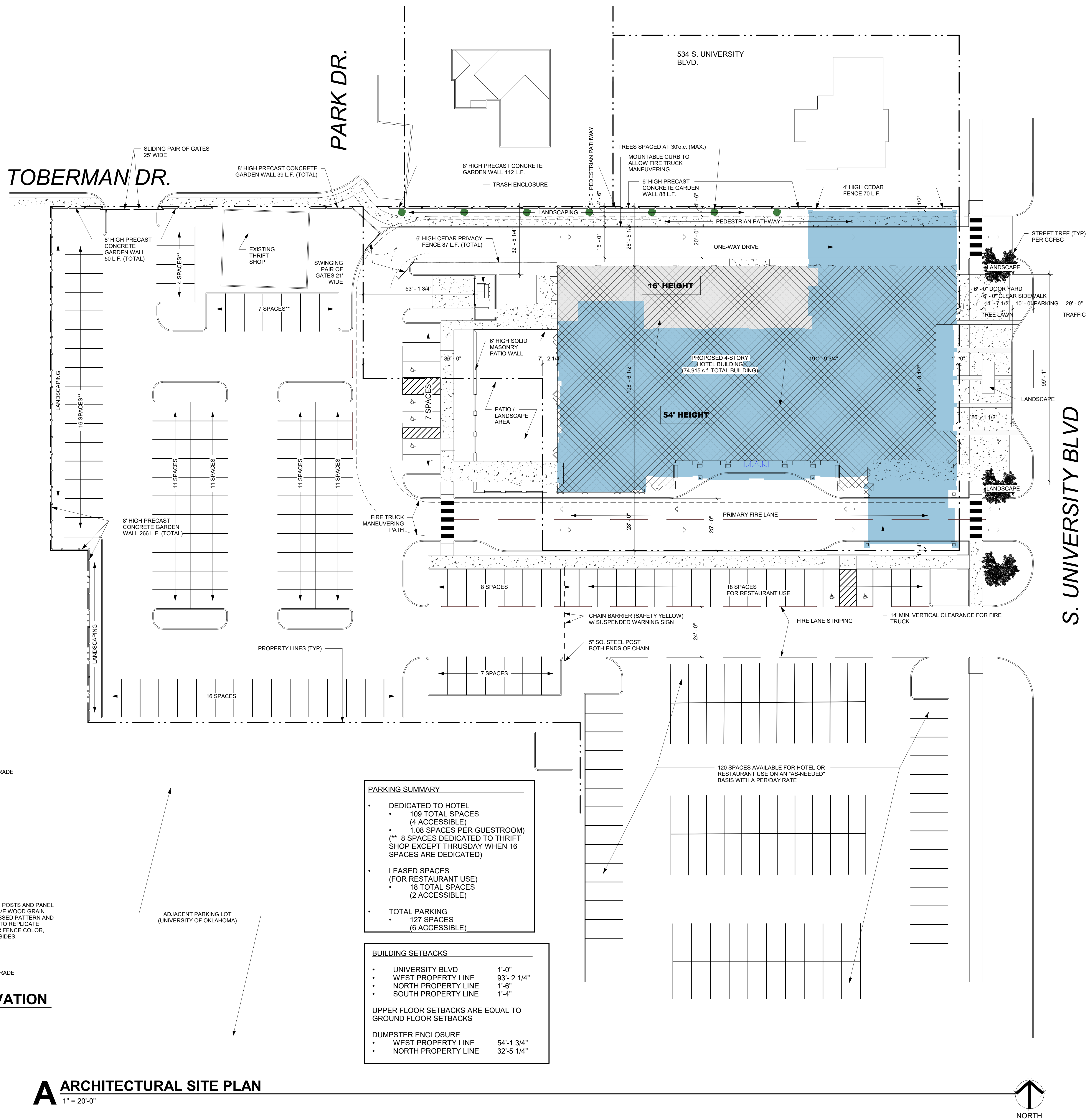
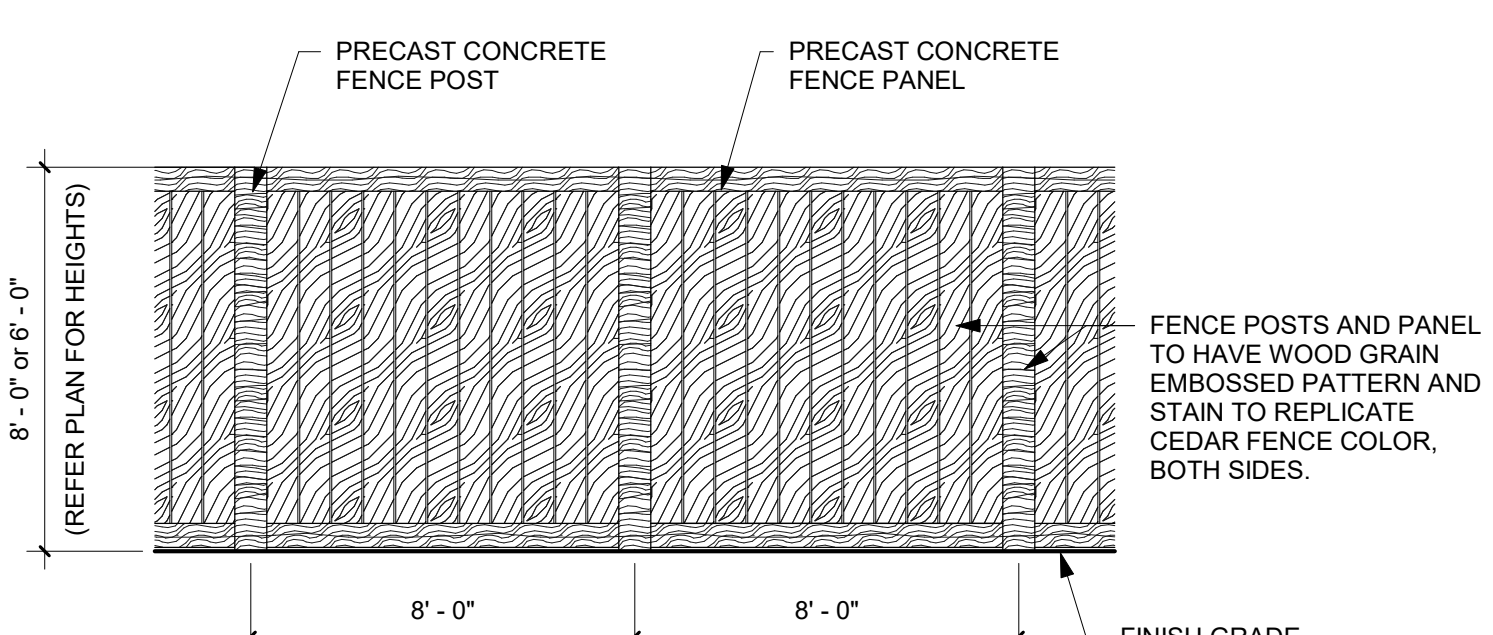

B PRECAST GARDEN WALL ELEVATION
 1/4" = 1'-0"

A ARCHITECTURAL SITE PLAN
 1" = 20'-0"

PARKING SUMMARY

- DEDICATED TO HOTEL
 - 109 TOTAL SPACES (4 ACCESSIBLE)
 - 1.08 SPACES PER GUESTROOM
 - (** 8 SPACES DEDICATED TO THRIFT SHOP EXCEPT THURSDAY WHEN 16 SPACES ARE DEDICATED)
- LEASED SPACES (FOR RESTAURANT USE)
 - 18 TOTAL SPACES (2 ACCESSIBLE)
- TOTAL PARKING
 - 127 SPACES (6 ACCESSIBLE)

BUILDING SETBACKS

- UNIVERSITY BLVD 1'-0"
- WEST PROPERTY LINE 93'-2 1/4"
- NORTH PROPERTY LINE 11'-8"
- SOUTH PROPERTY LINE 1'-4"

UPPER FLOOR SETBACKS ARE EQUAL TO GROUND FLOOR SETBACKS

DUMPSTER ENCLOSURE

- WEST PROPERTY LINE 54'-1 3/4"
- NORTH PROPERTY LINE 32'-5 1/4"

ADJACENT PARKING LOT (UNIVERSITY OF OKLAHOMA)