

# AIA<sup>®</sup> Document G701<sup>™</sup> – 2001

## Change Order

<b>PROJECT</b> (Name and address): Norman Public Library Central 103 West Acres Street Norman, OK 73069	<b>CHANGE ORDER NUMBER:</b> 002 <b>DATE:</b> September 8, 2017	<b>OWNER:</b> <input checked="" type="checkbox"/> <b>ARCHITECT:</b> <input checked="" type="checkbox"/> <b>CONTRACTOR:</b> <input checked="" type="checkbox"/> <b>FIELD:</b> <input type="checkbox"/> <b>OTHER:</b> <input type="checkbox"/>
<b>TO CONTRACTOR</b> (Name and address):	<b>ARCHITECT'S PROJECT NUMBER:</b> <b>CONTRACT DATE:</b> April 25, 2017 <b>CONTRACT FOR:</b> General Construction	

**THE CONTRACT IS CHANGED AS FOLLOWS:**

(Include, where applicable, any undisputed amount attributable to previously executed Construction Change Directives)  
PCO 4 r1 8.24.17: the work required for PR#1 costs incurred from changes to electrical, fire suppression, steel, and geo-pumps. Added credit for Hammer and costs for trap seals in this revision #1 - \$31,652

PCO 7: the work required to add wall framing to allow water closet hangers to be installed - \$1,593

Weather days: #4(08.01), #5(08.07), #6(08.11), #7(08.14), #8(08.17), #9(08.23), #10(08.25)

Total Cost: \$33,245  
Total Days: 7

The original Contract Sum was	\$ 25,858,000.00
The net change by previously authorized Change Orders	\$ 36,033.00
The Contract Sum prior to this Change Order was	\$ 25,894,033.00
The Contract Sum will be increased by this Change Order in the amount of	\$ 33,245.00
The new Contract Sum including this Change Order will be	\$ 25,927,278.00

The Contract Time will be increased by seven (7) days.  
The date of Substantial Completion as of the date of this Change Order therefore is

**NOTE:** This Change Order does not include changes in the Contract Sum, Contract Time or Guaranteed Maximum Price which have been authorized by Construction Change Directive until the cost and time have been agreed upon by both the Owner and Contractor, in which case a Change Order is executed to supersede the Construction Change Directive

**NOT VALID UNTIL SIGNED BY THE ARCHITECT, CONTRACTOR AND OWNER.**

<u>MGR</u> ARCHITECT (Firm name)	<u>Flintco, LLC</u> CONTRACTOR (Firm name)	<u>City of Norman</u> OWNER (Firm name)
<u>710 SOUTH 2ND ST. 8TH F.</u> ADDRESS	<u>2307 S. Prospect</u> ADDRESS	<u>201 W. Gray St.</u> ADDRESS
<u>[Signature]</u> BY (Signature)	<u>[Signature]</u> BY (Signature)	<u>[Signature]</u> BY (Signature)
<u>KRISTILYN VENCOWSIE</u> (Typed name)	<u>James A. Heley</u> (Typed name)	<u>Stevie D. Lewis</u> (Typed name)
<u>9/08/2017</u> DATE	<u>9/11/17</u> DATE	<u>9 Oct. 17</u> DATE

**MEMORANDUM**

Date: 9/8/2017  
Project Name: **Norman Central Branch Library**  
Project No: 2016005.00  
  
To: CO #002  
From: Thomas Haller (MSR)  
Cc: N/A

Re: **NORMAN EAST LIBRARY CO 002 EXPLANATIONS**

The descriptions below are intended to explain the reasons for each change stated in CO #002, and the associated costs for each change. Reference CO #002 for the formalized and signed document outlining these changes. Reference the potential change orders produced by Flintco for the origination of stated costs.

PCO #4r1 8.24.17 – \$31,652

Explanation: This work is required for PR#1 costs incurred from changes to electrical, fire suppression, steel, and geo-pumps. Also, credit was added for Hammer and costs for trap seals in this revision #1. MSR recommended.

PCO #7 – \$1,593

Explanation: This work is required to add wall framing, to allow water closet hangers to be installed. MSR recommended.

CO #002 Total Cost: \$33,245

**Thomas Haller, Associate**  
612.375.8708 T tom@msrdesign.com E



ADG, PC  
920 W Main  
Oklahoma City, OK 73106  
405.232.5700 • www.adgokc.com

## MEMO

DATE: 9/22/17  
TO: Terry Floyd  
FROM: ADG Team  
SUBJECT: NORMAN FORWARD – Central Library – Change Order #002

---

PROJECT: NORMAN FORWARD – Central Library

PROJECT NO: 16-003

PHASE NO: Construction

---

ADG has reviewed the summary of the referenced Change Order provided by MSR along with their explanation and estimate of cost for each item. ADG is in agreement with MSR's recommendations.

**Leslie Tabor**  
Program Management



ADG, PC  
920 W Main  
Oklahoma City, OK 73106  
405.232.5700



**CHANGE ORDER REQUEST: PCO 4r1**

Project Name: Norman Central Library  
 Flintco Job Number: 17039  
 MSR Job Number: 2016005  
 City of Norman Contract number: K-1617-83

<b>TO:</b> Terry Floyd Norman Municipal Authority 201 West Gray Norman, Ok 73070	<b>Subject:</b> PR # 1
--	------------------------

In Accordance with our contract agreement, for your review and acceptance, we submit this cost proposal

<b>Document Ref:</b> PR # 1	<b>NTP DATE:</b>
<b>Summary:</b> COR for PR #1 costs incurred from changes to electrical, fire suppression, steel, and geo-pumps. See page 2 for breakdown by subcontractor. Added Credit for Hammer and Costs for trap seals in this revision # 1.	<b>COR Date:</b> 8.24.17
<b>Exclusions:</b>	

<b>LABOR, LABOR BURDEN, MATERIALS, SUBCONTRACTS</b>		
Direct Labor		\$ -
Labor Burden	(49% *Sum of all Flintco Labor)	\$ -
Direct Materials		\$ -
Direct Subcontracts		\$ 26,034
<b>SUBTOTAL 1</b>		<b>\$ 26,034</b>
<b>EXPENSES ON LABOR AND MATERIALS</b>		
Consumables	(5.0% of Labor)	-
Small Tools	(5.0% of Labor)	-
<b>SUBTOTAL 2</b>		<b>\$ -</b>
<b>EXPENSES ON LABOR, LABOR BURDEN, MATERIALS</b>		
Data Processing	(0.25% of labor, burden, and materials)	-
Safety	(1.0% of labor, burden, and materials)	-
Warranty	(1.0% of labor, burden, and materials)	-
<b>SUBTOTAL 3</b>		<b>\$ -</b>
<b>SUBCONTRACTOR INSURANCE, OVERHEAD AND FEE</b>		
Subcontractor Bonding program	(1.5% of Subcontracts)	\$ 391
Bldrs Risk Insurance	(.08% of Subcontracts)	21
Overhead on Subcontracts	(10% of Subcontracts)	2,603
Fee on Subcontracts	(10% of Subcontracts)	2,603
<b>SUBTOTAL 4</b>		<b>\$ 5,618</b>
<b>SELF PERFORMED WORK INSURANCE, OVERHEAD AND FEE</b>		
Bonds and Bldrs Risk Insurance	(.6 % of Self Performed work)	\$ -
Overhead on Flintco Work	(10% of Self Performed work+ Bond / Ins)	\$ -
Fee on Flintco Work	(10% of Self Performed work+ Bond / Ins)	\$ -
<b>SUBTOTAL 5</b>		<b>\$ -</b>
<b>TOTAL CHANGE ORDER PROPOSAL</b>		<b>\$ 31,652</b>

Flintco, Inc.  
  
 James A. Meley  
 Date: 8/24/17

OWNER  
 Terry Floyd  
 Date



**CHANGE ORDER REQUEST:**

4r1

Oklahoma City, OK  
Job Number 17039 - Norman Central Library

**WORKSHEET**  
8.24.17

DESCRIPTION	QTY	UNIT	LABOR				MATERIAL		SUBCONTRACTOR		
			UMH	MHRS	RATE	U.P.	COST	U.P.	COST	U.P.	COST
Unique	1	LS		-		-	-		-	\$11,231	\$ 11,231.00
Prime	1	LS		-		-	-		-	\$10,541	\$ 10,541.00
P&L	1	LS		-		-	-		-	\$3,690	\$ 3,690.00
Quality	1	LS		-		-	-		-	(\$1,208)	\$ (1,208.00)
Quality Trap sealers	1	LS		-		-	-		-	\$3,578	\$ 3,578.49
Hammer Check Valves	1	LS		-		-	-		-	(\$1,798)	\$ (1,798.40)
				-		-	-		-		-
				-		-	-		-		-
				-		-	-		-		-
				-		-	-		-		-
				-		-	-		-		-
				-		-	-		-		-
				-		-	-		-		-
				-		-	-		-		-
				-		-	-		-		-
				-		-	-		-		-
				-		-	-		-		-
				-		-	-		-		-
<b>TOTAL</b>								\$0	\$0	\$	26,034.09

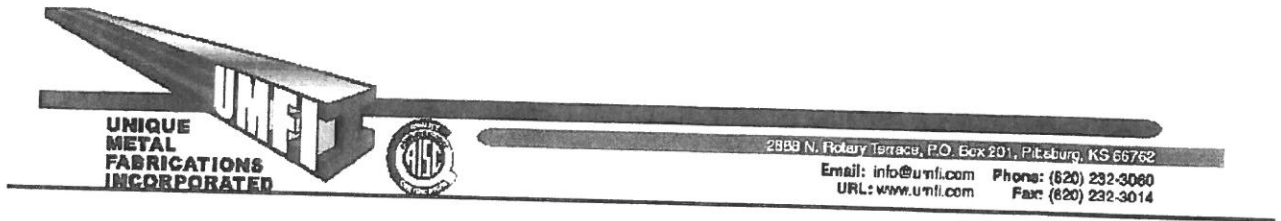

## COR 001

Revision 0

Date: 7-28-17  
Job Number: M1732  
Norman Central Library  
Norman, Ok.

### Add Price Description

Add material and labor to make revisions per PR-01

Changes include but are not limited to the following:

- S102: Upsized W24x55 to W27x84.
- S104: Revised joist sizes.
- S104: Added connection loads.
- S104.1: Added pipe post and bracing per 14/S521.
- S104.2: Added connection loads.
- S105: Added connection loads
- S401: Revised bracing loads.

Please issue a change order for \$11,231 for this work in order to avoid any delays in deliveries.

**Proposal Breakdown:**

• Add material:	\$3360
• Add drafting labor	\$1000
• Add shop labor:	\$3450
• Joist and deck add	\$900
• Add mgt. labor:	\$500
• Add engineering calc. cost	\$1000
• Add freight	<u>\$0000</u>
Subtotal:	\$10,210
P & O (10%)	<u>\$1021</u>
Total:	\$11,231

---

DM

Project Manager

UNIQUE METAL FABRICATIONS, INC

---

Buyer

General Contractor

**PRIME ELECTRIC CO.** / 400 S. Coltrane, Edmond, OK 73034 • (405) 359-9190

TO: Flintco Construction  
 Project Norman Public Library Central  
 COR No. 1  
 COR Title PR #1

Expires 7/14/2017

COR Date 7/5/2017

Revision Date

COR Item No	Description	Qty	Material	Labor		Equipment	
				Hours	Costs	Type	Cost
1	3-#3 THHN	(70')	(333.06)	(4.55)	\$ (194.51)	DJE	\$ (14.59)
2	3-#4 THHN	70'	264.67	3.99	\$ 170.57	DJE	\$ 12.79
3	Ditch & Compacted Backfill	220'	1744.60	20.24	\$ 865.26	DJE	\$ 64.89
4	4" SCH 80 PVC	150'	1001.55	21.00	\$ 897.75	DJE	\$ 67.33
5	3-Cell Fabric Innerduct	160'	813.92	2.08	\$ 88.92	DJE	\$ 6.67
6	3/4" EMT	60'	60.60	4.32	\$ 184.68	DJE	\$ 13.85
7	3-#12 THHN	70'	47.39	1.68	\$ 71.82	DJE	\$ 5.39
8	Plan Review			2.44	\$ 104.31	DJE	\$ 7.82
9	Plot Plans/Update As-Builts/Update Field Set		153.72	7.69	\$ 328.75	DJE	\$ 24.66
10	Safety Coordination/Documentation			4.60	\$ 196.65	DJE	\$ 14.75
11							
12							
13							
14							
15							
16							
17							
18							
19							
20							
21							
22							
23							
24							
25							
26							
27							
<b>Totals</b>			<b>\$ 3,753.39</b>	<b>63.49</b>	<b>\$ 2,714.20</b>		<b>\$ 203.56</b>
					<b>Labor Burden</b>	<b>\$ 1,108.75</b>	
<b>Total Raw Costs (Labor+Labor Burden+Material+Equipment+Tax)</b>							<b>\$ 7,779.90</b>
<b>Project Management Expense</b>							<b>\$ -</b>
<b>Sales Tax - No</b>							<b>\$ -</b>
<b>Overhead @ 10%</b>							<b>\$ 777.99</b>
<b>Profit @ 5%</b>							<b>\$ 427.89</b>
<b>Supervision</b>							<b>\$ 1,349.16</b>
<b>Bonds - Yes</b>							<b>\$ 206.70</b>
<b>GRAND TOTAL</b>							<b>\$ 10,541.65</b>

**NOTES:**  
 Proposal excludes cutting, patching, or painting of any surface unless specifically included above.  
 Proposal assumes all work to be performed during normal working hours and does not include any overtime unless show  
 No work to begin until written authorization for this proposal.





# P & L Fire Protection, Inc.

5518 East Hwy. 37 Tuttle, OK 73089  
P: (405) 381-3385 F: (405) 381-3387  
Oklahoma State License: 0126

## BID PROPOSAL

**Date:** July 11, 2017

**Contractor:** Flintco, Incorporated Ph: 405 670-6307 Fax: 405 670-6568  
2302 S. Prospect Oklahoma City OK 73129  
[okcestimating@flintco.com](mailto:okcestimating@flintco.com) [cristine.winchester@flintco.com](mailto:cristine.winchester@flintco.com)

**Project:** Norman Public Library Central  
Norman, OK

**Item of Quote:** Add a backflow preventer at riser

**Scope of work:** Labor and materials necessary to add a backflow at the riser per PR-1.

**Quote amount:** \$ 3,690.00

Labor:	\$	295.00
Materials:	\$	2,950.00
Expenses:	\$	100.00
OH&P:	\$	345.00
<b>Total:</b>	<b>\$</b>	<b>3,690.00</b>

**Estimator:** Jairo Soto



## Norman Public Library Central

TOTAL MATERIAL/SUB COST		<u>1,655.38</u>
TOTAL LABOR COST		<u>869.50</u>
TOTAL OTHER DIRECT COST		<u>432.55</u>
	TOTAL PRICE	<u>2,957.43</u>
OVERHEAD <u>10%</u>		<u>295.74</u>
	SUBTOTAL	<u>3,253.17</u>
PROFIT <u>10%</u>		<u>325.32</u>
BOND		<u>-</u>
	TOTAL PRICE	<u>3,578.49</u>

DATE August 16, 2017 FIRM NAME Quality Plumbing & Heating

TITLE President BY \_\_\_\_\_  
(signature)

We Agree hereby to make the change (s) specified above at this price \$3,578.49

PREVIOUS CONTRACT AMOUNT \$ \_\_\_\_\_

REVISED CONTRACT AMOUNT \$ \_\_\_\_\_

### ACCEPTANCE OF CHANGE ORDER

DATE \_\_\_\_\_ FIRM NAME \_\_\_\_\_

TITLE \_\_\_\_\_ BY \_\_\_\_\_  
(authorized signature)



# The Green Solution

## 2" SureSeal<sup>®</sup> MODEL #SS2009V

### INLINE FLOOR DRAIN TRAP SEALER



**Specification:** SureSeal model SS2009V Waterless Inline 2" Drain Trap Seal. HDPE (High Density Poly Ethylene) housing with heavy duty proprietary silicone diaphragm and soft EPDM rubber sealing gasket. Floor rating ASSE 1072 AF GW.

**Function:** Installs into the outlet of drain bodies, or drain hubs to protect the trap seal from evaporation. Creates a physical barrier that blocks sewer gases and their odors from escaping. Provides waterless trap seal protection equivalent to water based trap primers.

- **New Construction:** Used as a trap primer replacement or in conjunction with a trap primer to provide protection against escaping sewer gases. Eliminates the need to repair/replace trap primers when they fail.
- **Retrofit:** Used in situations where trap primers have failed or where trap primers were never installed.

**Benefits:** Simple to install, eliminates the need for complex, time consuming, and expensive repairs. ECO friendly providing 100% water savings efficiency over traditional methods.

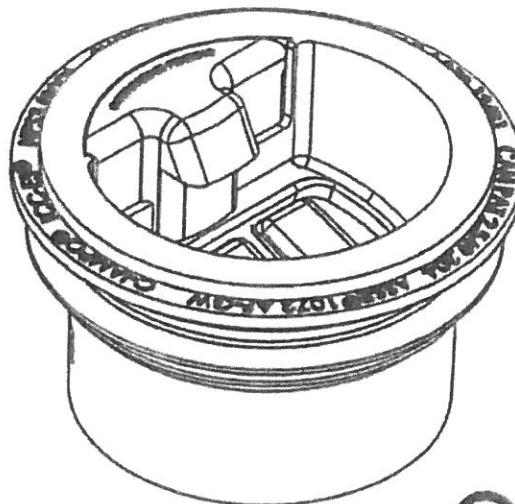
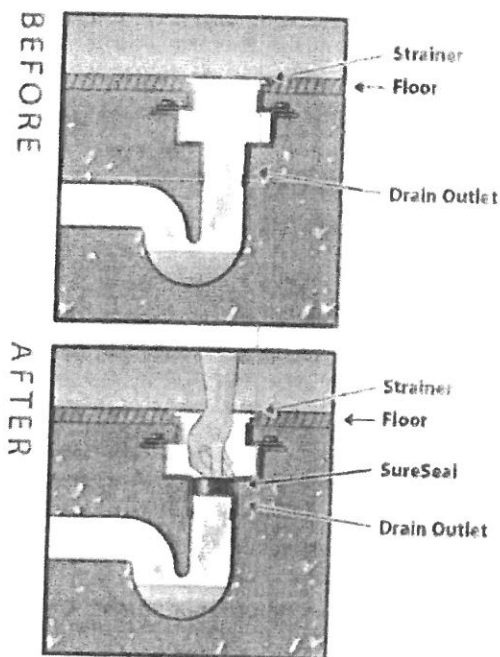

ICC-ES Listed: PMG-1070 IAPMO Listed: C-4165

U.S. Patent 9,010363 Other Patent Pending

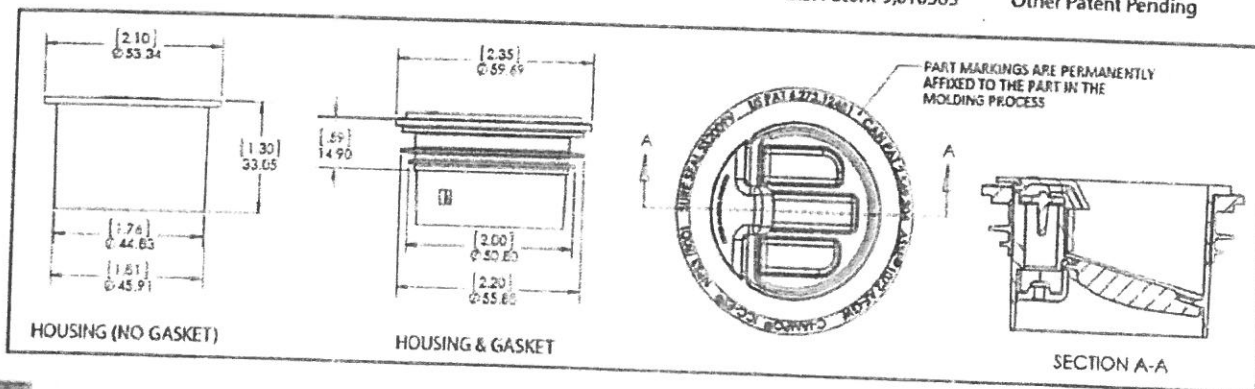

Contact RectorSeal<sup>®</sup> 2601 Spanwick Drive, Houston, TX 77055 ☎ 713-263-8001 ☎ 800-231-9345 ☎ 713-263-7577 ☎ 800-441-0051 🌐 [rectorseal.com](http://rectorseal.com)



PO Box 721078 Norman, OK 73070

Phone: (405) 310-3160  
Fax: (405) 310-3161

**CHANGE ORDER REQUEST**

PROJECT: Norman Central Library	CHANGE ORDER	
	PO:	
DATE: 8/9/2017	CONTRACT DATE:	6/11/2017
PREPARED BY: Brian Brewer	CONTRACT FOR:	Flintco

**Description of change**

**Changes in Quantities**

3" Double Check Valve	
Labor for check valve	(5898.40)
4' Concrete Box for check valve	(5150.00)
Labor on concrete box	(5550.00)
	(5200.00)

**Total Cost:** (51,798.40)

All terms and Conditions shall remain as originally written unless modified herein.

Not valid until signed by the Owner and Contractor.

The original (Contract Sum) (Guaranteed maximum Price) was \_\_\_\_\_  
 Net change by previously authorized Change orders \_\_\_\_\_  
 The (Contract Sum) (Guaranteed maximum Price) prior to this Change order was \_\_\_\_\_  
 The (Contract Sum) (Guaranteed maximum price) will be by this Change Order in the amount of \_\_\_\_\_  
 The new (Contract Sum) (Guaranteed maximum Price) including this Change order will be \_\_\_\_\_

The Contract Time will be (increased) decreased) (unchanged) by \_\_\_\_\_  
 The date of Substantial Completion as of the date of this Change Order therefore is \_\_\_\_\_

Hammer Construction, Inc  
 CONTRACTOR  
 BY Brian Brewer  
 DATE 7/27/2017 8/9/17

OWNER \_\_\_\_\_  
 BY \_\_\_\_\_  
 DATE \_\_\_\_\_



**CHANGE ORDER REQUEST: PCO**

Project Name Normon Central Library  
 Flintco Job Number 14664

MSR Job Number 2016005

City of Normon Contract number K-1617-83

<b>TO:</b> Terry Floyd Norman Municipal Authority 201 West Gray Norman, Ok 73070	<b>Subject:</b> PR # 2 - Wall layout changes & water closet hangers
--	--

In Accordance with our contract agreement, for your review and acceptance, we submit this cost proposal

Document Ref: PR # 2	NTP DATE: COR Date: 8/29/2017
Summary: This COR is to add wall framng to allow water closet hangers to be installed.	
Exclusions:	

**LABOR, LABOR BURDEN, MATERIALS, SUBCONTRACTS**

Direct Labor		\$ -
Labor Burden (49% *Sum of all Flintco Labor)		\$ -
Direct Materials		\$ -
Direct Subcontracts		\$ -

**SUBTOTAL 1**

\$ 1,310

**EXPENSES ON LABOR AND MATERIALS**

Consumables (5.0% of Labor)		-
Small Tools (5.0% of Labor)		-

**SUBTOTAL 2**

\$ -

**EXPENSES ON LABOR, LABOR BURDEN, MATERIALS**

Data Processing (0.25% of labor, burden, and materials)		-
Safety (1.0% of labor, burden, and materials)		-
Warranty (1.0% of labor, burden, and materials)		-

**SUBTOTAL 3**

\$ -

**SUBCONTRACTOR INSURANCE, OVERHEAD AND FEE**

Subcontractor Bonding program (1.5% of Subcontracts)		-
Blders Risk Insurance (.08% of Subcontracts)		\$ 20
Overhead on Subcontracts (10% of Subcontracts)		1
Fee on Subcontracts (10% of Subcontracts)		131

**SUBTOTAL 4**

\$ 283

**SELF PERFORMED WORK INSURANCE, OVERHEAD AND FEE**

Bonds and Bldrs Risk Insurance (.6 % of Self Performed work)		\$ -
Overhead on Flintco Work (10% of Self Performed work+ Bond / Ins)		\$ -
Fee on Flintco Work (10% of Self Performed work+ Bond / Ins)		\$ -

**SUBTOTAL 5**

\$ -

**TOTAL CHANGE ORDER PROPOSAL**

**\$ 1,593**

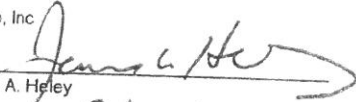
Flintco, Inc  
  
 James A. Heley  
 Date 8/29/17

OWNER  
 \_\_\_\_\_  
 Terry Floyd  
 \_\_\_\_\_  
 Date





P.O.Box 54985, OKC., OK 73154  
 Phone 405-840-8377 Fax 405-840-1096  
 Description for Change:  
 PR 002 - Toilet Partition type changes.

Change Order No. Two to Contract K-1617-83

Date: 8/7/2017  
 Proposal Request #: 1  
 Project: Norman PC Library  
 Location: Norman, OK.  
 Work: No Incurred

Materials	Cost Code	Unit	Unit Cost	Total
3-5/8" Stud & Track	701300M	610 lf	0.48	292.80
3-5/8" Slotted track	701300M	40 lf	1.40	56.00
				0.00
				0.00
				0.00
Tools / Fasteners	701038G	1 ea	15.00	15.00
		Sales Tax	8.750%	31.83
<b>Subtotal</b>				<b>395.63</b>

Labor	Cost Code	Unit	Unit Cost	Total
Journeyman framing	701300L	16 /hr	35.00	560.00
Journeyman	701300L	/hr		0.00
Journeyman		/hr		0.00
Journeyman		/hr		0.00
Overtime		/hr		0.00
Perdium		/day		0.00
PM / Supervisor	701051	1 /hr	50.00	50.00
<b>Subtotal</b>				<b>610.00</b>

Equipment	Cost Code	Unit	Unit Cost	Total
Scissor lift 19'	701037G	1 /wk	60.00	60.00
Boom lift 40'	701037G	/day		0.00
		Sales Tax	8.750%	5.25
<b>Subtotal</b>				<b>65.25</b>

Subcontractors	Cost Code	Total

**Inclusions:**

- Cleanup to a central location
- Equipment for our work only

**Exclusions:**

- Trash Removal from Site & Trash Receptacles
- All Rough Carpentry, Blocking & Backing
- All Tape, Bed & Paint
- All Caulking, Sealants & Grouting
- All Attachment by Bolting or Welding
- All premium expense /OT as a result of any acceleration of schedule or as a result of delays caused by others is excluded.
- All temporary enclosures, lighting, ventilation, heating &/or utilities

Total Raw Costs		1,070.88
Gen Req'ments, Insurance, Bond	2%	21.42
Subtotal		1,092.30
OH/Profit	20%	217.70
		0.00
<b>Total Change Order Proposal</b>		<b>1,310.00</b>

CO due Date \_\_\_\_\_

Timberlake Interiors reserves the right to withdraw this pricing if not accepted in writing within (30) days of the date of this proposal. *CO's must be received by our office within (15) days after work is completed or PR issue date.* Additional work will only be performed and furnished following a written change order signed by GC & Timberlake Interiors.

Accepted By Authorized Agent: \_\_\_\_\_  
 Date: \_\_\_\_\_